

AGP-10H Handoperated Grouting Pump

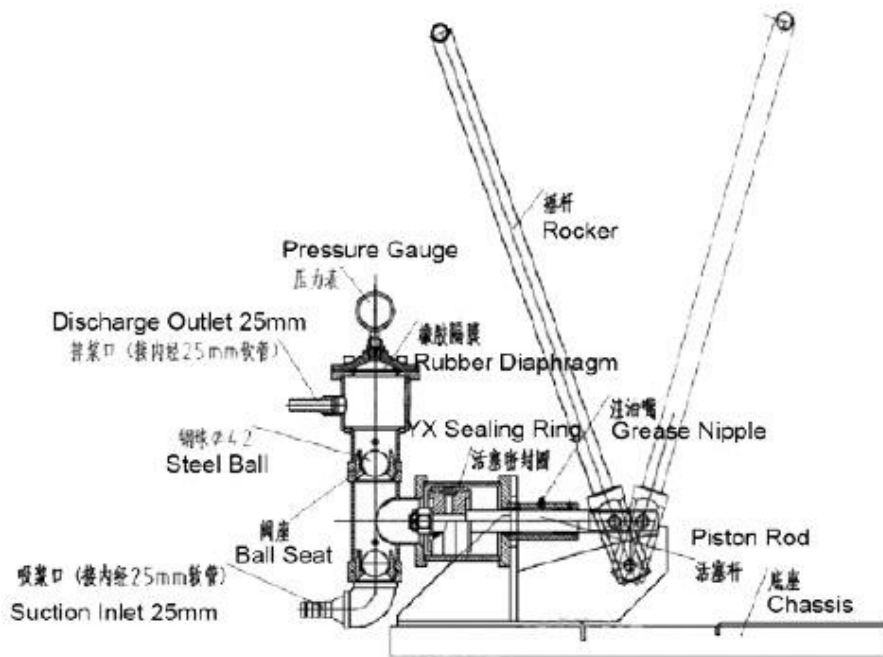

AGP-10H Hand Grouting Pump Structure drawing



结构图 Structure Drawing

AGP-10H Hand Grouting Pump Introduction:

AGP-10H Hand-operation Grouting Pump is mainly used in grouting cement slurry or the similar slurry. It is very popular for the crack repair of the bridge engineering, house construction, etc.

AGP-10H Hand Grouting Pump Features:

- Manual grouting, simple operation and controllable flow.
- Single-cylinder work, high vacuum degree, and strong self-suction capability.
- Small size and light weight, convenient for moving in a small space.
- Repair and maintain easily and fewer consumable parts.

AGP-10H Hand Grouting Pump Technical Data Sheet

Output	0-8 L/min
Rated Working Pressure	1 Mpa
Cylinder Dia	110mm
Piston stroke	42mm
Outlet diameter	25mm
Inlet diameter	25mm
Dimensions	980×290×590mm
Weight	40kg
Chassis	Skid
Note: With rocker, the height is 1065mm	

The information contained in this document is believed to correct but A.E.G(Wuxi) Machinery Co., Limited accepts no liability for any errors it contains, and reserves the right to alter specifications without notice. Please consult the respective machine manual for all matters related to operations and maintenance.