

AGP60/40 Mechanical Piston Grouting Pump

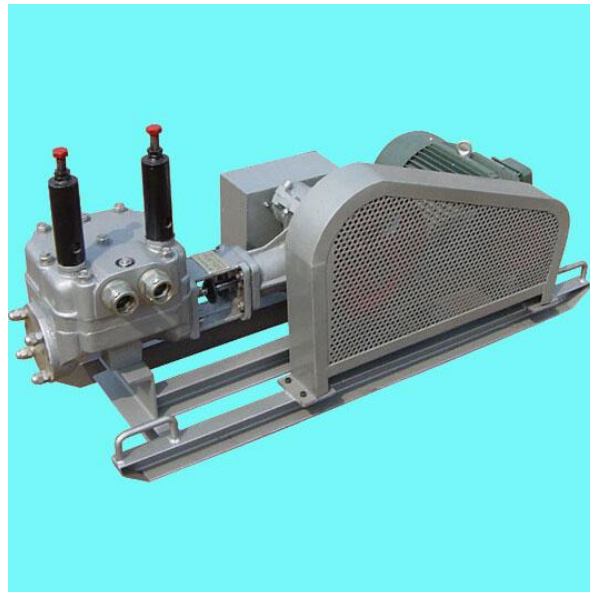

AGP60/40 Mechanical Piston Grouting Pump Introduction:

AGP60/40 is a piston-grouting pump for the processing of middle pressure grouting. It is suitable for grouting with either of single slurry and two different slurries. It can be used for tunnels, slope, mining, bridge and all sorts of underground engineering etc.

AGP60/40 Mechanical Piston Grouting Pump Features:

- Single piston double acting
- Gear&vee belt transmission makes this pump high mechanical efficiency and working reliability
- Integrated valve house and ball valve, together with compact structure.
- Can complete double slurry grouting and single slurry grouting.

AGP60/40 Mechanical Piston Grouting Pump Technical Data Sheet

Output	60 L/min (3.6m ³ /h)
Rated Working Pressure	4 Mpa (40kgf/cm ²)
Cylinder Dia	75 mm
Piston stroke	85 mm
Piston Speed	85 times/min
Outlet diameter	38 mm
Inlet diameter	42 mm
Motor Power	5.5kW
Dimensions	1280mm * 485mm * 645mm
Weight	210kg

AGP60/40 Mechanical Piston Grouting Pump Structure and setting dimension:

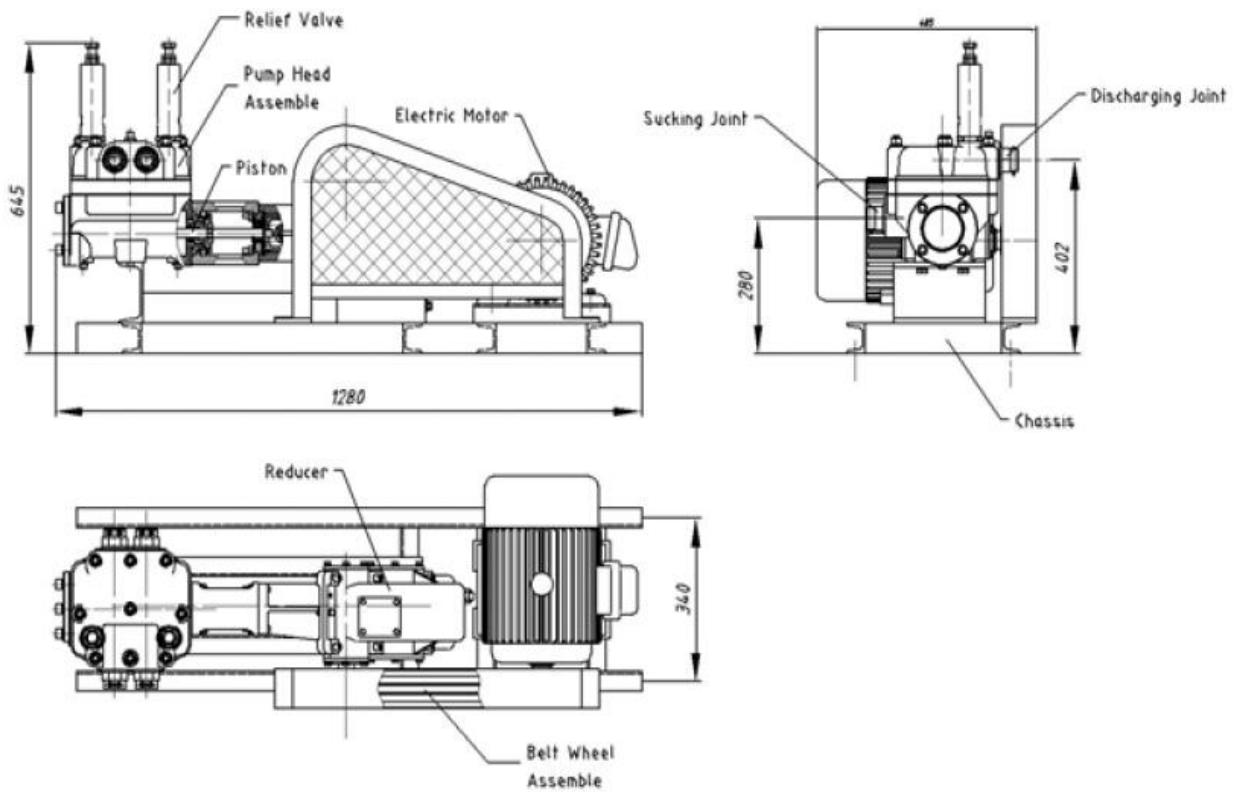

AGP60/40 Mechanical Piston Grouting Pump head assemble:



The information contained in this document is believed to correct but A.E.G(Wuxi) Machinery Co., Limited accepts no liability for any errors it contains, and reserves the right to alter specifications without notice. Please consult the respective machine manual for all matters related to operations and maintenance.